

APPLICATION SCENARIOS



Shopping Mall



Retail



Billboard

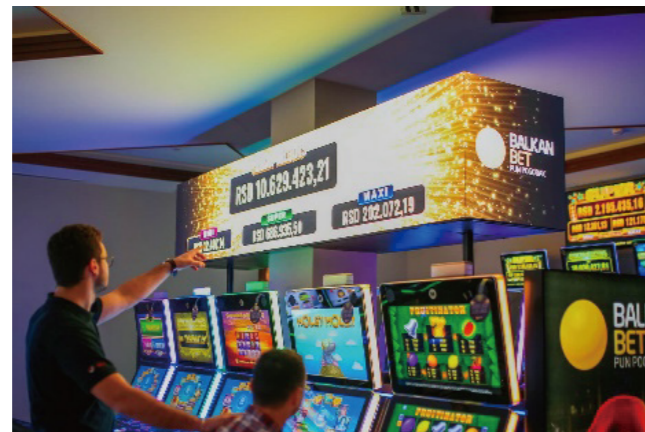

Casino

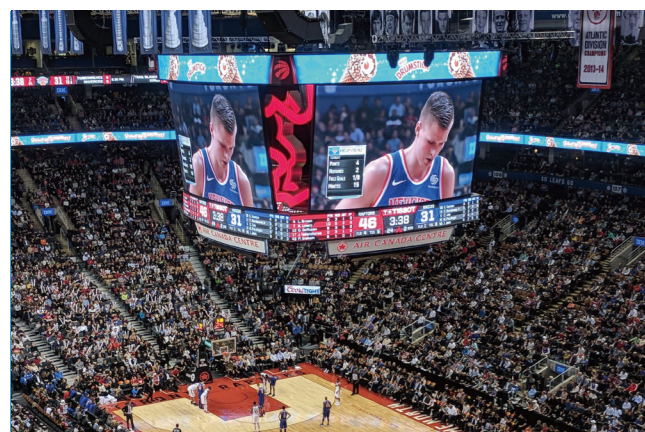

Score Board



Airport



AURORA DISPLAYS

Aurora Signage PTY LTD

Tel : +61 1300 841 542

,E-mail: sales@aurorasignage.com.au

,Web : www.aurorasignage.com.au



AURORA DISPLAYS

LDC500XX Series Indoor LED Display Systems

INTRODUCTION

Product Features

- Available Pixel Pitch 1.9|2.6|2.9|3.9mm
- Brightness 700nits
- High-precision Die-cast Aluminum Panel
- Panel Dimensions 500mm*500mm*70mm
- GOB Optional

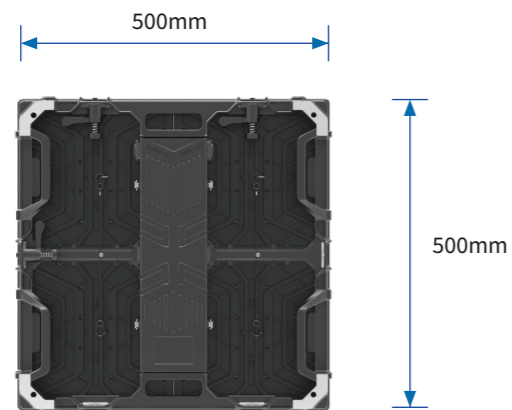

3840

High Refresh Rate

7kg

Weight Only 7kg



One Man Installation



Front/Rear Maintenance



CE | FCC | RoHS

High-precision Panel Design

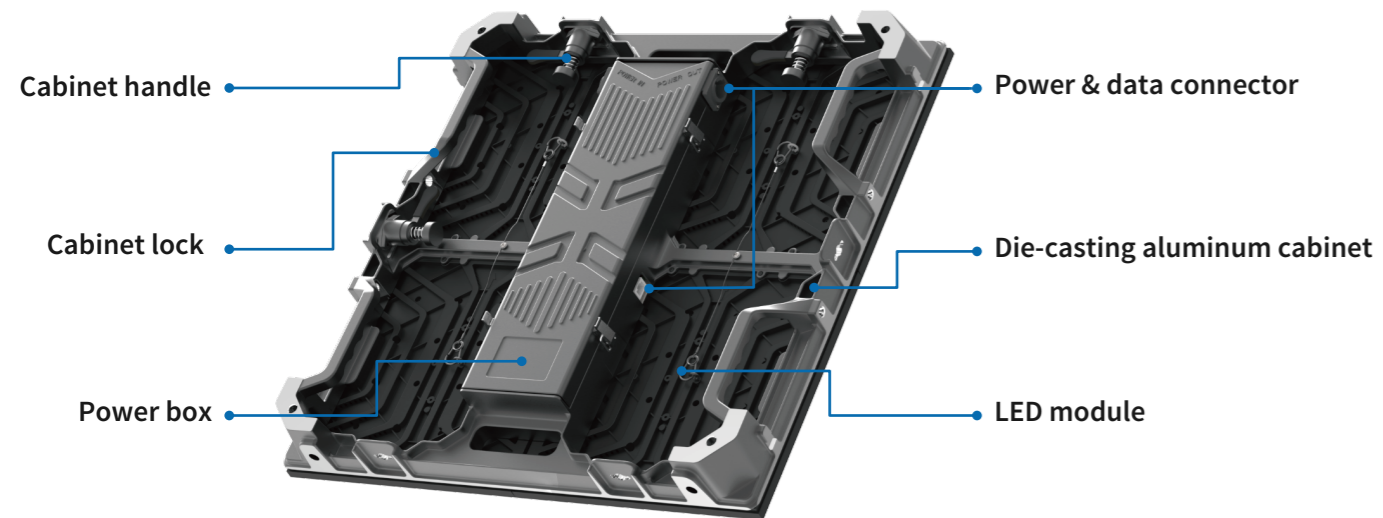

Convenient Maintenance

Fast front and rear maintenance of LED module.



Front



Rear

Industrial-grade LED Module



Module Bottom



4 Layer PCB Board



Mask Protection(P2.9|3.9)

Perfect Visual Experience

Higher Visual Uniformity

Pixel-by-pixel calibration technology eliminates the difference in brightness and chromaticity within and between panels, improving the uniformity of display.



Clearly Visible under Low Brightness

High grayscale level under low brightness ensures the details of the image are clearly visible.



Delicate and Smooth Video

3840Hz high refresh rate eliminates streaks on the screen, enhances the clarity and contrast of the image, making the video picture delicate and smooth.



Vivid Color Displaying

HDR processing technology enhances image quality and vivid color displaying.



SPECIFICATIONS

Model	LDC50019SFP	LDC50026FP	LDC500297FP	LDC500391FP
Pixel Pitch	1.9mm	2.6mm	2.9mm	3.9mm
LED Type	SMD	SMD	SMD	SMD
Module Size(mm)	250*250	250*250	250*250	250*250
Module Resolution	128*128	96*96	84*84	64*64
Cabinet Size(mm)	500*500*70	500*500*70	500*500*70	500*500*70
Cabinet Resolution	256*256	192*192	168*168	128*128
Cabinet Weight(kg/pcs)	7	7	7	7
Brightness(nits)	600-1000	600-1000	600-1000	600-1000
Cabinet Material	Die-cast aluminum	Die-cast aluminum	Die-cast aluminum	Die-cast aluminum
Viewing Angle	160°/140°	160°/140°	160°/140°	160°/140°
Contrast	5000:1	5000:1	5000:1	5000:1
Refresh Rate	3840Hz	3840Hz	3840Hz	3840Hz
Gray Scale Processing	14bit	14bit	14bit	14bit
Input Voltage	AC 100 to 240V, 50/60Hz	AC 100 to 240V, 50/60Hz	AC 100 to 240V, 50/60Hz	AC 100 to 240V, 50/60Hz
Input Power(Avg)	163	164	164	166
Input Power(Max)	489	490	490	500
Maintenance Mode	Front/rear maintenance	Front/rear maintenance	Front/rear maintenance	Front/rear maintenance
Ingress Protection	Front/rear IP30/IP30	Front/rear IP30/IP30	Front/rear IP30/IP30	Front/rear IP30/IP30